

use your  
**inner eye**



**Lenses by Carl Zeiss**



We make it visible.



**For over 160 years, ...**

As one of the world's leading companies in the optical and opto-electronic industry, with a workforce of more than 12,000 employees, Carl Zeiss is internationally regarded as the trendsetter in each of its fields of expertise: in microelectronics and measuring technology, medicine and ophthalmology, photography and binoculars

More than 20 Nobel Laureates have used Carl Zeiss microscopes for research in biology, medicine and pharmacology. Carl Zeiss is equally influential in the field of genetic and viral research as in nanotechnology. Carl Zeiss visualization systems for industrial metrology and chemical analyses are used for monitoring processes and provide precision measurements to a thousandth of a millimeter.

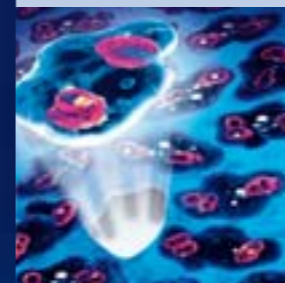

*Whether in the operating room, treating defective vision, or in microscopy research, Carl Zeiss technology helps to save lives, cure diseases, and simply make life more worth living.*



*Whether cell phones, laptops or USB sticks: every second microchip is produced using semi-conductor lenses from Carl Zeiss – the highest performing lenses in the world.*



*Every day all over the world, visitors to planetariums are given breathtaking demonstrations of just how far Carl Zeiss' eye can see. Carl Zeiss projectors depict the universe with maximum precision.*

**... making your visions visible**



*With its excellent binoculars and scopes, Carl Zeiss reveals the secrets of our world, and of nature in particular, in close-up – in all their infinite fascination.*

Almost everyone comes in contact with innovative technologies by Carl Zeiss in their everyday lives. They make the invisible visible, allow us to experience our environment more intensively, to see and show things with greater clarity and precision. Innovations by Carl Zeiss not only help to enhance the quality of our lives, but also to make our modern world a better place – today and in the future.

**We make it visible.**

Carl Zeiss

## Lenses by Carl Zeiss

Every second, somewhere in the world, a customer chooses a Carl Zeiss lens. Engineers, film producers and photographers all know and appreciate the quality and performance of our products.

ZEISS lenses are at home in the widest range of applications: in industry, movie production, journalism and photographic studios; in webcams on PCs and in cell phones. This amazing spectrum of expertise and experience enables us to develop future-oriented products that are precisely tailored to the needs of everyone who uses them – for unbeatable results and unforgettable experiences.



*From movies to cell phone lenses: we are all daily witnesses to the exceptional performance of ZEISS lenses.*



*Carl Zeiss cine lenses have helped many famous films such as "Lord of the Rings", "King Kong" and "Perfume" to create their fabulous images, and have twice been awarded the "Technical Oscar".*



*From space missions to quality assurance on the production line: excellent, special purpose lenses from Carl Zeiss provide reliable, high-quality image information.*

## Use your inner eye



New impressions enrich our lives every day. Our inner eye connects perception and memory, idea and reality. Every photographer, whether professional or amateur, creates a mental picture in his or her inner eye before pressing the release button – by choosing subject, perspective, mood, light and atmosphere. Technology is there to capture the photographer's creation. Real, emotional, and without compromise.

ZEISS lenses and cameras give the photographer control over every aspect of the composition. And yet they are easy and intuitive to use: with the user-friendly, precise focusing mechanism and high quality metal mounts, the large, bright viewfinder image that provides every item of information, and with the fast, quiet shutter. Reliable functions ensure that photographers are able to fully concentrate on the picture and composition and their creative powers. Snapshots document the spirit of the moment, record facts, and provide certainty. People and subjects are captured in settings that are both moving and lasting.

Carl Zeiss Camera Lenses



## Intuition is your trigger

It's time for precision. For personalized photography. For intuitive use and exceptional images. For creative composition and intriguing perspectives. Time for an SLR lens by Carl Zeiss.

SLR cameras display exactly what the lens records: the image section, the depth of field and the effect of various perspectives. This means that a picture can be structured with deliberate, planned precision, but with the creative freedom to experiment. With their bright, high-contrast viewfinder image, the exact, precise focusing system, superbly balanced bokeh, all supported by extraordinarily high-contrast color rendition and an outstanding 3D effect in the image, SLR lenses by Carl Zeiss offer many creative possibilities for personalized manual composition.

It is the subtlety, those fine points of detail, that distinguish a good shot from an excellent one. Personalized photography is the integration of your own personality and creativity into the perfect picture, irrespective of the automatic mechanisms of your camera. Professional photographers see and sense when the inner eye and the lens connect, opening the door to a unique form of artistic expression.



**Carl Zeiss SLR Lenses**



## Precision ...



### Precise focusing

Operating a lens manually means controlling the picture with your fingertips. Ergonomics are everything.

- large rotary angle for pinpoint focusing
- high quality, smooth focusing mechanism without play
- immediate display of changes in the viewfinder
- precise engraving in meters and feet

### Optimum results

ZEISS lenses are famous for the exceptional quality of the pictures they provide. No matter how demanding the subject, perspectives, colors, and lighting situations are reproduced perfectly – over the entire full-frame image field.

- T\* anti-reflex coating by Carl Zeiss
- stray light reduction for rich colors
- minimized reflection and color fringes
- optimum distortion correction
- standardized color characteristics over all focal lengths

### Ideal aperture

The finely matched properties of the aperture ensures that the effects of out-of-focus areas of the picture are attractively balanced (bokeh).

- 9 blades create an almost circular aperture
- adjustable in 1/2 f-stop intervals (for ZE depending on camera)
- aperture ring with easy-to-detect lock-in positions and precise photometric grading



## ... makes all the difference

### Mechanical durability

With excellence you can feel and quality that will last, ZEISS lenses are perfect for decades of intensive use.

- all-metal mounts
- practical focusing and aperture setting ring in metal
- sturdy front bayonet and filter thread



### Compatible camera interface

The SLR lenses are suitable for analog and digital SLR cameras and optimized for full-format. They are available for five connection types.

- ZE: Lenses with EF bayonet and electronic aperture coupling as well as CPU coupling for Canon SLR cameras.
- ZF.2: Lenses with F bayonet and mechanical aperture coupling as well as CPU coupling for Nikon, Fujifilm or Kodak SLR cameras.
- ZF: Lenses with F bayonet and mechanical aperture coupling for Nikon, Fujifilm or Kodak SLR cameras.
- ZK: Lenses with K bayonet and mechanical aperture coupling for Pentax or Samsung SLR cameras.
- ZS: Lenses with M42 screw thread for adapters of different SLR camera systems.

For further information on compatibility, go to [www.zeiss.com/photo](http://www.zeiss.com/photo)



## Carl Zeiss SLR Lenses



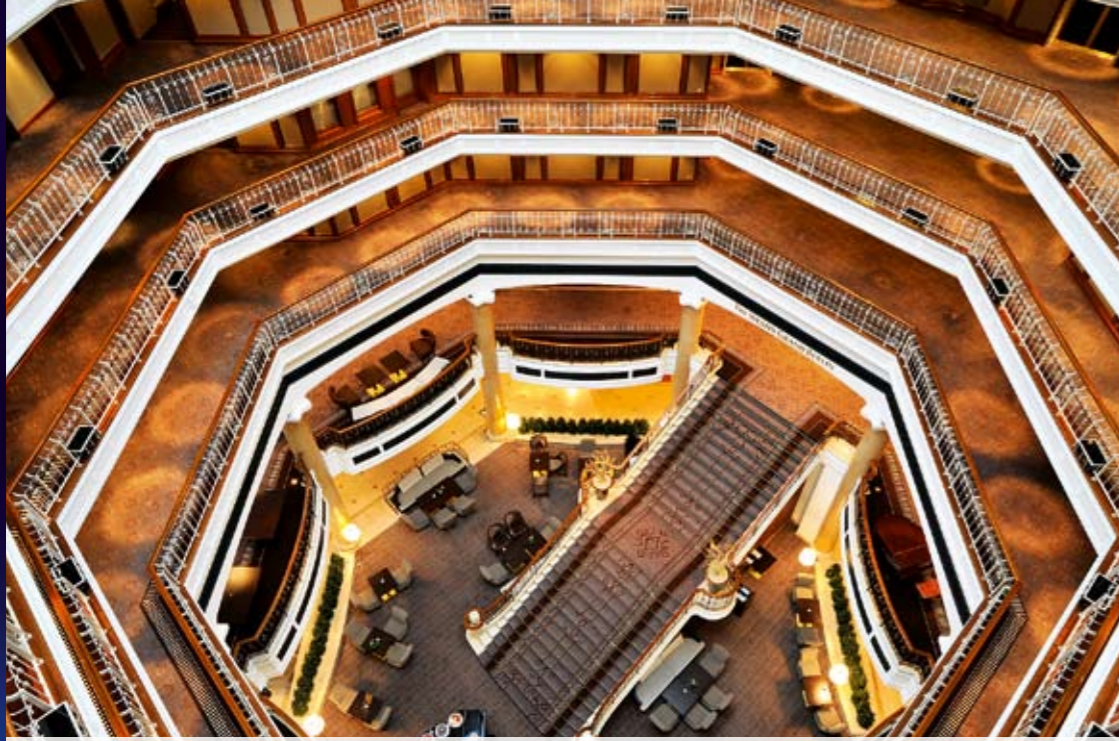

**Michael Wartmann**

"The architecture of the Westin Grand Hotel foyer in Berlin has a very interesting, symmetric perspective, which is interrupted by the staircase in the basement. Thanks to the Distagon T\* 2,8/21 ZF, I could photograph the foyer at large. Despite the wide image circle of 90°, the lens also captured all details of the image borders as for example the wing below which is displayed very sharp and precise."

**Westin Grand Hotel, Berlin** SLR camera with F bayonet and Distagon T\* 2,8/21 ZF

### What photographers say



**Frank Love**

"On this occasion I remember how nice the light was and telling my friend Dan to hold still for a moment. I already had the lens set at T1.4 and had an idea for the shutter-speed from the previous shots, so I focused on his eyes and snapped the shot. Lenses by Carl Zeiss are an influence on me because I have to take precise care when taking each photograph. These aren't automatic lenses, they don't find things for me, and that's what I love about them."

**My friend Dan** SLR camera with F bayonet and Planar T\* 1,4/50 ZF



**Gabi Budulig**

"Macro photography opens up foreign worlds; abstraction is created through the omission of image components anchored in visual habits. And suddenly, something unique, unusual and exciting is created from everyday subjects. What appears as a creature from another world is an orchid found on many window sills. With the Makro-Planar T\* 2/100 ZF, I can dive into these worlds. In my studio I make them visible for the viewer with monochrome backgrounds and selective illumination. The brilliance of this lens enables to show each of the tiny details."

**Orchid Phalaenopsis** SLR camera with F bayonet and Makro-Planar T\* 2/100 ZF

**Carl Zeiss SLR Lenses**



## Fascination starts in your mind

Many people prefer the road less taken. They would rather follow their passion, and trust their inner eye. They see the unusual and do the unexpected. The Zeiss Ikon impresses with its creative strength, the freedom and intimacy of rangefinder photography. It really pushes the optical and mechanical boundaries of a rangefinder camera. Photographers see more than what the lens captures: they have the entire surroundings in view and can therefore respond spontaneously.

The Zeiss Ikon is so compact, discreet and uncomplicated that it captures situations, especially people centered scenes, with particular authenticity. ZM lenses by Carl Zeiss echo this strength, and create first-class results of exceptional clarity and with optimum aberration correction. The camera and the lenses combine classic design with simple operation. They enable the photographer to control a maximum of aspects when composing a picture. Every picture reflects the fascination of an entirely personal perspective.



**Zeiss Ikon System**



## Zeiss Ikon System

### New perspectives ...

#### Bright, large viewfinder

The viewfinder image is particularly bright and wide, and includes all the information the photographer needs: the recommended and set shutter time and the respective viewfinder frame with the focal length (28, 35, 50 and 85 mm). Special anti-reflective coatings result in a particularly brilliant viewfinder image and triangulation field without stray light.

#### Precision rangefinder

The Zeiss Ikon has the widest rangefinder base on the market. Thanks to an entirely new design, the viewfinder display is extremely large and remains in the middle of the rangefinder when focusing.



#### Convenient exposure metering

The lighting situation is measured by centered-weighted TTL exposure metering. The shutter speed is selected automatically and displayed in the viewfinder display; it can be corrected using the dial on the top of the camera.

A separate button is available to transfer the exposure metering value for several successive shots. If the speed is chosen manually, both the selected and the recommended shutter speeds are displayed.

#### Intuitive operation

The operating concept inspires creative photography and facilitates the spontaneous implementation of imaginative ideas. It permits very fast, simple settings, and prevents disruptions and interruptions during photography.

### ... sharpen your senses



#### Excellent image quality

All ZM lenses by Carl Zeiss have the T\* anti-reflex coating and an optical design that produces brilliant pictures, even in unfavorable lighting conditions. The pictures are free from distortion and aberrations.

#### Ideal aperture properties

The lens aperture with 10 blades has easy-to-feel, lock-in positions in precise 1/3 f-stop intervals. The almost circular aperture helps to create a particularly harmonious effect in the out-of-focus areas of the picture (bokeh).

#### Smooth, precise focusing

The user-friendly focusing ring on ZEISS lenses with an ergonomic finger rest is perfect for fast, precise focusing.

#### Robust design

The mount and control elements of all ZM lenses are made of metal and are designed for decades of intensive use.







Mongolia Zeiss Ikon camera with Biogon T\* 2/35 ZM



**Sven Zellner**

"This motive emerged during my stay in Mongolia. At that moment, I was able to photograph freehand into the sunset with a shutter speed of 1/4 second. In this case, it was an advantage that the Zeiss Ikon Camera does not have a very strong movement during the shutter release. Therefore, the pictures are not blurry and all details even the ones in the shade are clearly visible."

**What photographers say**



Backstreets Analog rangefinder camera and Planar T\* 2/50 ZM



**Colin Jones**

"I try to take pictures with the feeling it's what your eyes would see if you were standing there. Recording the nuances of a scene is not always easy but I rely on the Planar T\* 2 / 50 ZM to capture even the faintest of details. It's my lens of choice for photographing the little seen parts of China with its superb image clarity that after years of use genuinely still manages to surprise me."



Child with soft toy Zeiss Ikon camera with C Sonnar T\* 1,5/50 ZM



**Michael Ankenbrand**

"Several of the most impressive photos of recent decades were created by limiting technology to a minimum. This is the only way to capture the magic of the moment without annoying illumination devices, allowing full concentration on the subject, in this case a little boy. Nothing interrupts the contact between the model and the photographer. However, working with available light at open aperture requires precise focusing on the most important points in the image in a matter of seconds. The bright triangulation rangefinder on the Zeiss Ikon is a valuable assistant for this situation. The selected depth of field of the fast C Sonnar T\* 1,5/50 ZM allows the eyes of the child to dominate the picture while the entire surroundings swim in a soft blur, thus enabling the crisply focused image elements to appear even more brilliant."

**Zeiss Ikon System**

## Professional cleaning and maintenance

In order to guarantee the high quality and precision of our lenses, they undergo a number of extensive cleaning processes using special fluids throughout production. And so that you can care for your valuable equipment whether you are at home or out and about, we offer our accurately designed cleaning products. Our Lens Cleaning Kit comes not only with the cleaning fluid, but also with a dust brush, microfiber cloth, 10 pre-moistened wipes and a set of instructions for professional lens care. The components are all kept conveniently close at hand in a high quality, fabric belt pouch. The cleaning fluid, microfiber cloths and wet wipes are also available separately.



*Cleaning optics the proper way: Carl Zeiss Lens Cleaning Kit*

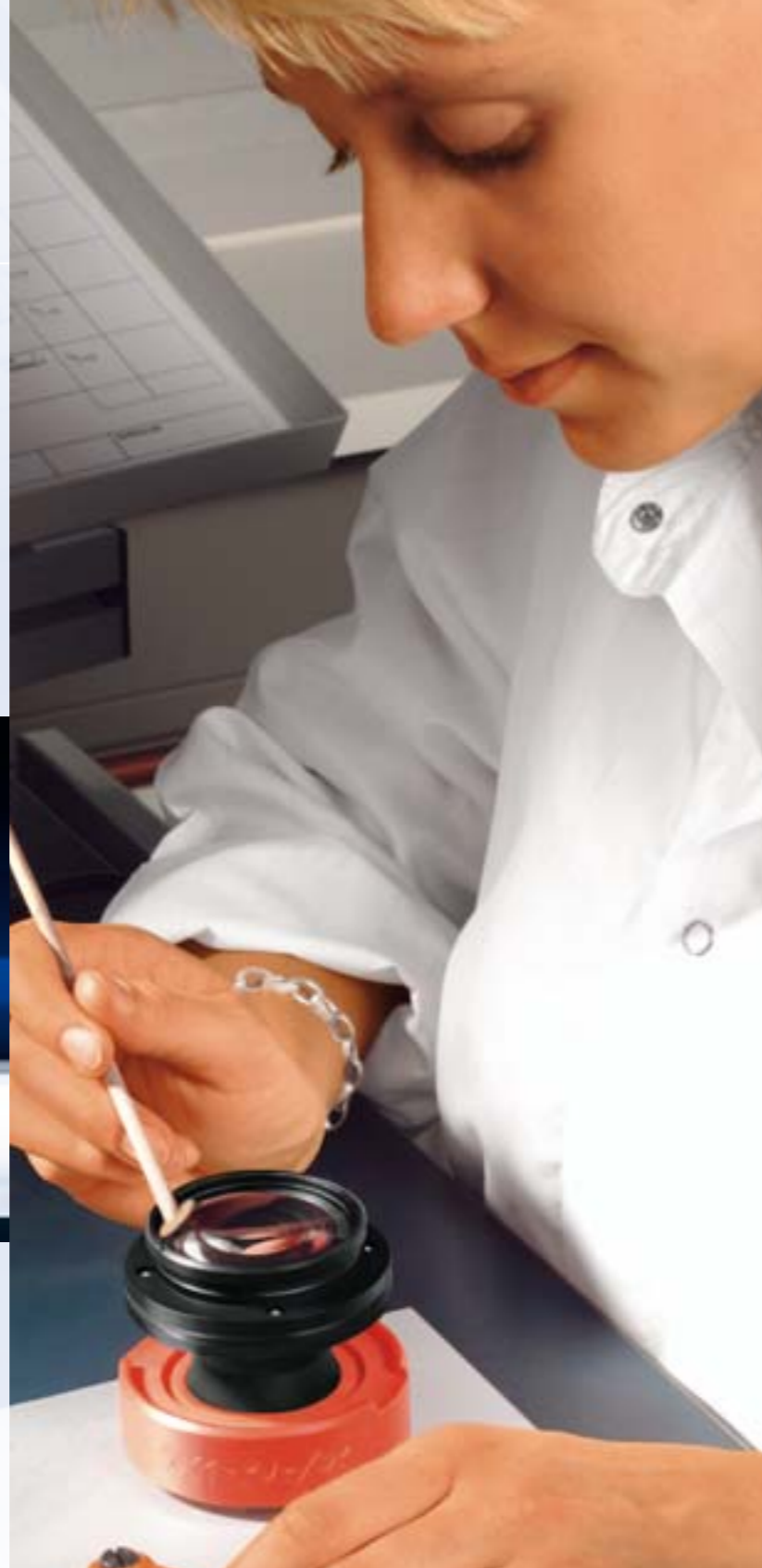

## Eye to eye with Carl Zeiss

Our qualified specialist dealers are your contact for any questions you may have in regard to maintenance and care, service and warranty issues. To find your local Carl Zeiss dealer, please go to the list provided on our website.

- Internet [www.zeiss.com/photo](http://www.zeiss.com/photo)
- E-Mail [photo@zeiss.de](mailto:photo@zeiss.de)
- Telephone +49 (0) 73 64-20-61 75



*Carl Zeiss Headquarters in Oberkochen, Germany*

**Carl Zeiss Lens Cleaning Kit**

**[www.zeiss.com/photo](http://www.zeiss.com/photo)**



**Carl Zeiss AG**  
**Camera Lens Division**  
D-73446 Oberkochen · Germany  
[www.zeiss.com/photo](http://www.zeiss.com/photo)



*EN\_10\_010\_001 III • Printed in Germany*  
Kodak  [www.kodak.de](http://www.kodak.de)

Carl Zeiss SLR Lenses

# Distagon T\* 2/28

## The Famous High-speed Artist

This moderate wide-angle lens is based on the renowned Distagon design of the 1980s for the Contax system. The modern **Distagon T\* 2/28** has been optimized with current, higher performing and eco-friendly glass and incorporates a floating lens element design to optimize image quality across the entire focusing range. A compact lens for its speed, the fast f/2 aperture allows for hand-held photography under difficult lighting conditions and is well-suited for landscape, nature and commercial photography. Combined with a DSLR with a 1.5 crop factor, the lens has an effective focal length of 42 mm.



Picture shows ZE mount

## Distagon T\* 2/28



We make it visible.



**1** Takes captivating wide-angle pictures, even under difficult lighting conditions.

**2** The integrated floating elements design ensures consistent performance at any distance.

**3** Optimal control of glare and stray light ensures brilliant and brightly colored images.

Photo: Sabine Unterderweide

## The Famous High-speed Artist

### Technical Specifications

#### Distagon T\* 2/28

<b>Focal length</b>	28 mm
<b>Aperture range</b>	f/2 – f/22 (1/2 stop intervals)
<b>Number of elements/groups</b>	10/8
<b>Focusing range</b>	0.24 m (0.79 ft) – ∞
<b>Angular field* (diag./horiz./vert.)</b>	74/65/45°
<b>Coverage at close range</b>	18 x 12 cm (7.1 x 4.7")
<b>Image ratio at close range</b>	1:4.7
<b>Filter-thread</b>	M 58 x 0.75
<b>Length (with caps)**</b>	93 - 96 mm (3.7 - 3.8")
<b>Diameter**</b>	64 - 72.4 mm (2.5 - 2.6")
<b>Weight**</b>	520 - 580 g (18 - 20 oz.)
<b>Camera mounts</b>	ZE (EF bayonet) ZF.2 (F bayonet with CPU) ZF (F bayonet) ZK (K bayonet)
<b>Scope of delivery</b>	Lens Shade included

\*referring to 35 mm format

\*\*dimensions and weight may vary according to the camera mount

### Construction

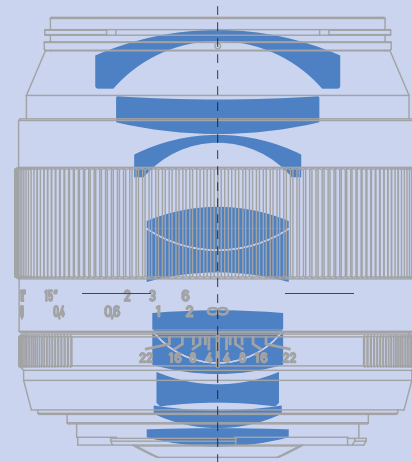

**Carl Zeiss AG**  
**Camera Lens Division**  
 D-73446 Oberkochen · Germany  
[www.zeiss.com/photo](http://www.zeiss.com/photo)

EN\_10\_022\_105 III • Printed in Germany  
 Subject to change.

Carl Zeiss SLR Lenses

# Distagon T\* 2/35

## The Versatile Reporter

This classic focal length with a moderate wide-angle perspective is perfectly suited for commercial, location and nature photography. The **Distagon T\*2/35** is designed to provide very high image quality over a wide range of apertures and focusing ranges. The fast f/2 aperture enables hand-held photography under difficult lighting conditions and the short focus rotation is well-suited for fast action photography. Combined with a DSLR with a 1.5 crop factor, the lens has an effective focal length of 53 mm and can be used as a standard focal length for a natural viewing perspective.



Picture shows ZE mount

## Distagon T\* 2/35



We make it visible.



- 1** Focal length and fast f/2 aperture, well-suited for reportage style photography.
- 2** The lens design and Carl Zeiss T\* anti-reflection coating allow for strong back lighting without affecting the image quality.
- 3** The new optical design with 9 lens elements ensures high imaging performance over the entire image area.

Photo: Michael Wartmann

## The Versatile Reporter

### Technical Specifications

#### Distagon T\* 2/35

<b>Focal length</b>	35 mm
<b>Aperture range</b>	f/2 – f/22 (1/2 stop intervals)
<b>Number of elements/groups</b>	9/7
<b>Focusing range</b>	0.3 m (0.98 ft) – ∞
<b>Angular field* (diag./horiz./vert.)</b>	62/53/37°
<b>Coverage at close range</b>	19 x 13 cm (7.5 x 5.1")
<b>Image ratio at close range</b>	1:5.3
<b>Filter-thread</b>	M 58 x 0.75
<b>Length (with caps)**</b>	97 - 99 mm (3.8 - 3.9")
<b>Diameter**</b>	64 - 72.2 mm (2.5 - 2.8")
<b>Weight**</b>	530 - 570 g (19 - 20 oz.)
<b>Camera mounts</b>	ZE (EF bayonet) ZF.2 (F bayonet with CPU) ZF (F bayonet) ZK (K bayonet) ZS (M42 screw mount)
<b>Scope of delivery</b>	Lens Shade included

\*referring to 35 mm format

\*\*dimensions and weight may vary according to the camera mount

### Construction

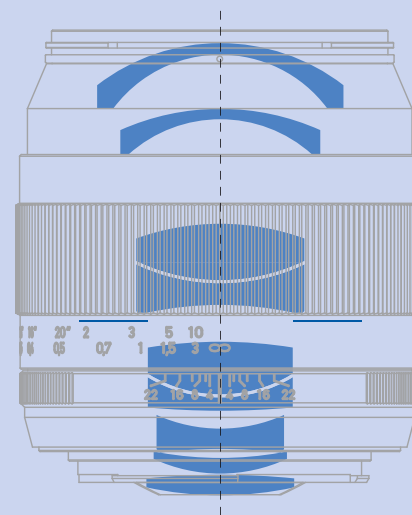

**Carl Zeiss AG**  
**Camera Lens Division**  
 D-73446 Oberkochen · Germany  
[www.zeiss.com/photo](http://www.zeiss.com/photo)

EN\_10\_022\_106 III • Printed in Germany  
 Subject to change.

Carl Zeiss SLR Lenses

# Distagon T\* 2,8/21

## The New Horizon

This legendary super wide angle lens will set new standards in its focal length class. Exceptional color control allows for extraordinary high contrast pictures without any color fringes. Thanks to the Carl Zeiss T\* anti-reflection coating and its outstanding attenuation of stray light, the **Distagon T\* 2,8/21** provides brilliant results under all lighting conditions. With a close focusing of only 0.22 m (0.72 ft) it is as attractive for landscape photography as for subjects with dramatic perspectives. The large front filter diameter allows for the use of standard screw-in filters and effective lens shades.



Picture shows ZE mount

## Distagon T\* 2,8/21



We make it visible.





- 1 Ideal color control resulting in color fringe-free pictures even along high-contrast contour-edges.
- 2 Optical design with floating elements for high performance at all focus distances, right up to the image edges.
- 3 Optimal control of glare and stray light ensures brilliant and brightly colored images.

Photo: Maiwolf Photography

## The New Horizon

### Technical Specifications

#### Distagon T\* 2,8/21

<b>Focal length</b>	21 mm
<b>Aperture range</b>	f/2.8 – f/22 (1/2 stop intervals)
<b>Number of elements/groups</b>	16/13
<b>Focusing range</b>	0.22 m (0.72 ft) – ∞
<b>Angular field* (diag./horiz./vert.)</b>	90/81/59°
<b>Coverage at close range</b>	18 x 12 cm (7.1 x 4.7")
<b>Image ratio at close range</b>	1:5
<b>Filter-thread</b>	M 82 x 0.75
<b>Length (with caps)**</b>	109 - 112 mm (4.3 - 4.4")
<b>Diameter**</b>	87 mm (3.4")
<b>Weight**</b>	600 - 720 g (21 - 25 oz.)
<b>Camera mounts</b>	ZE (EF bayonet) ZF.2 (F bayonet with CPU) ZF (F bayonet) ZK (K bayonet)
<b>Scope of delivery</b>	Lens Shade included

\*referring to 35 mm format

\*\*dimensions and weight may vary according to the camera mount

### Construction

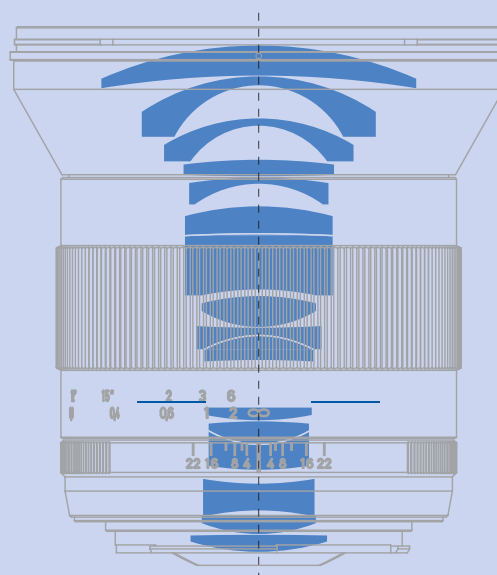

Carl Zeiss AG  
 Camera Lens Division  
 D-73446 Oberkochen · Germany  
[www.zeiss.com/photo](http://www.zeiss.com/photo)

EN\_10\_022\_102 III • Printed in Germany  
 Subject to change.

Carl Zeiss SLR Lenses

# Distagon T\* 3,5/18

## Focusing on the Perfect Moment

This ultra wide angle lens is ideal for capturing breathtaking moments in dramatic perspectives. The **Distagon T\* 3,5/18** offers excellent image performance over the entire image field. The precision floating elements design offers constant high performance over the entire distance range from 0.3 m (0.98 ft) to infinity. Optimum reflection absorption combined with the Carl Zeiss T\* anti-reflection coating allow for brilliant pictures even under difficult lighting conditions. Extremely contrasting edges are captured without color fringes due to the optimal color correction. Even combined with a digital SLR using a DX type sensor, this lens has an effective focal length of 27 mm, providing an interesting wide angle perspective. Above all, it is an ideal tool for landscape, architecture and commercial photographers.



## Distagon T\* 3,5/18

Picture shows ZE mount



ZE ZF.2 ZF ZK



We make it visible.



1 Optimum reflection absorption for brilliant pictures even under difficult lighting conditions.

2 Excellent image performance over the entire image field.

3 Optimal color correction for extremely contrasting edges without color fringes.

Photo: Sabine Unterderweide  
Expedition GeForce, Holiday Park Hassloch/Pfalz

## Focusing on the Perfect Moment

### Technical Specifications

#### Distagon T\* 3,5/18

Focal length	18 mm
Aperture range	f/3.5 – f/22 (1/2 stop intervals)
Number of elements/groups	13/11
Focusing range	0.3 m (0.98 ft) – ∞
Angular field* (diag./horiz./vert.)	99/90/67°
Coverage at close range	44 x 29 cm (1.7 x 1.1")
Image ratio at close range	1:12
Filter-thread	M 82 x 0.75
Length (with caps)**	84 - 85 mm (3.3")
Diameter**	87 mm (3.4")
Weight**	470 - 510 g (16 - 18 oz.)
Camera mounts	ZE (EF bayonet) ZF.2 (F bayonet with CPU) ZF (F bayonet) ZK (K bayonet)
Scope of delivery	Lens Shade included

\*referring to 35 mm format

\*\*dimensions and weight may vary according to the camera mount

### Construction

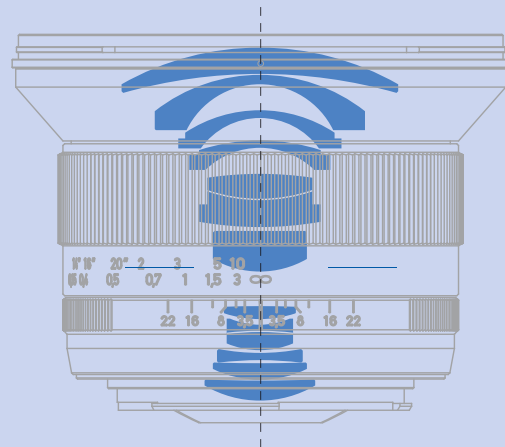

Carl Zeiss AG  
Camera Lens Division  
D-73446 Oberkochen · Germany  
[www.zeiss.com/photo](http://www.zeiss.com/photo)

EN\_10\_022\_135 III • Printed in Germany  
Subject to change.

Carl Zeiss SLR Lenses

# Planar T\* 1,4/50

## The Brilliant Glimpse

This bright and compact standard lens has a precise manual focusing mechanism and large rotation angle for precise control. The **Planar T\* 1,4/50** is designed for medium and longer distances and provides high-performance wide open, which only improves as the lens is stopped down. The lens construction controls flare and ghosting artifacts, resulting in a brilliant image with excellent contrast and natural color rendition. Combined with a DSLR with a 1.5 crop factor, the lens becomes a compact, lightweight 75 mm portrait lens.



Picture shows ZE mount

## Planar T\* 1,4/50



We make it visible.

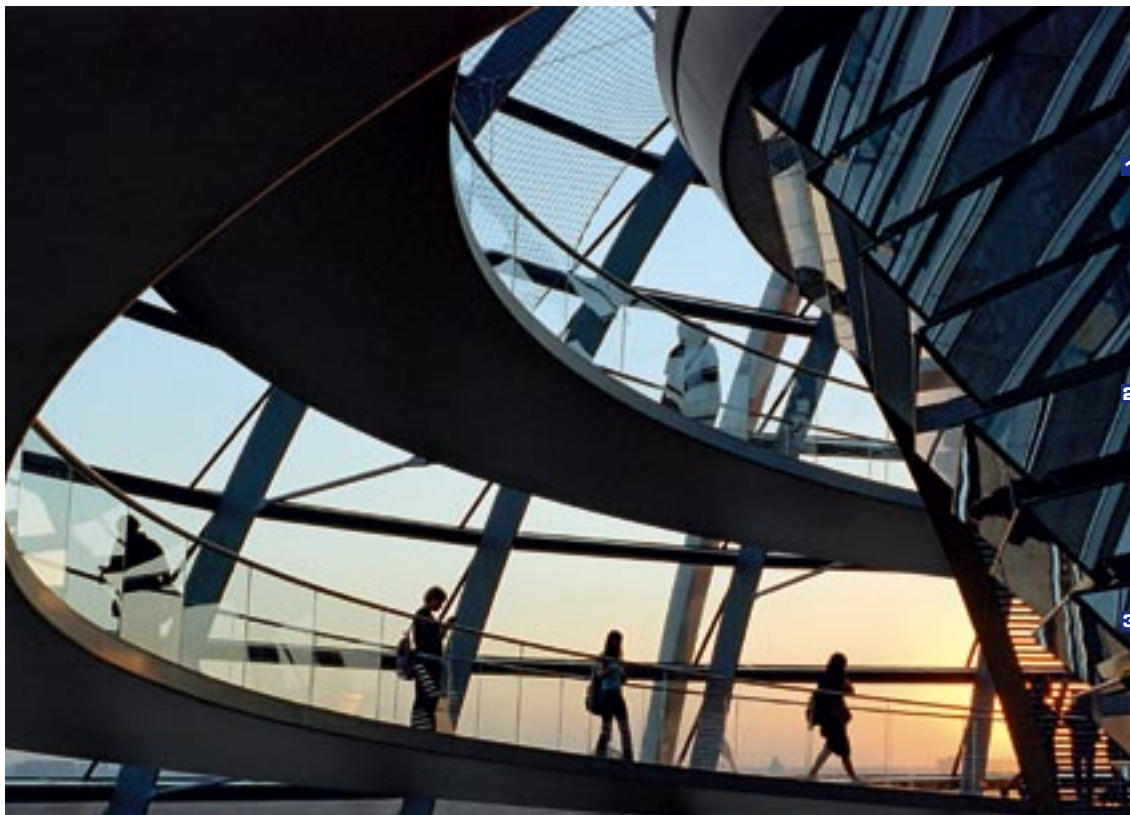

**1** The standard focal length captures images with the natural perspective of the human eye.

**2** The fast f/1.4 aperture produces impressive images even under difficult lighting conditions.

**3** When mounted on digital SLR cameras with smaller sensors (APS-C), it becomes a compact, lightweight portrait lens.

Photo: Michael Wartmann

## The Brilliant Glimpse

### Technical Specifications

#### Planar T\* 1,4/50

<b>Focal length</b>	50 mm
<b>Aperture range</b>	f/1.4 – f/16 (1/2 stop intervals)
<b>Number of elements/groups</b>	7/6
<b>Focusing range</b>	0.45 m (1.5 ft) – ∞
<b>Angular field* (diag./horiz./vert.)</b>	45/38/26°
<b>Coverage at close range</b>	24 x 16 cm (9.4 x 6.3")
<b>Image ratio at close range</b>	1: 6.7
<b>Filter-thread</b>	M 58 x 0.75
<b>Length (with caps)**</b>	69 - 71 mm (2.7 - 2.8")
<b>Diameter**</b>	66 - 71.3 mm (2.6 - 2.8")
<b>Weight**</b>	350 - 380 g (12 - 13 oz.)
<b>Camera mounts</b>	ZE (EF bayonet) ZF.2 (F bayonet with CPU) ZF (F bayonet) ZK (K bayonet) ZS (M42 screw mount)
<b>Scope of delivery</b>	Lens Shade included

\*referring to 35 mm format

\*\*dimensions and weight may vary according to the camera mount

### Construction

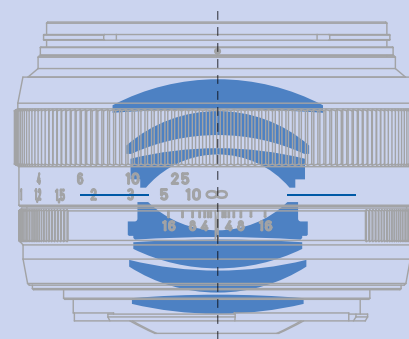

**Carl Zeiss AG**  
**Camera Lens Division**  
 D-73446 Oberkochen · Germany  
[www.zeiss.com/photo](http://www.zeiss.com/photo)

EN\_10\_022\_100 III • Printed in Germany  
 Subject to change.

Carl Zeiss SLR Lenses

# Planar T\* 1,4/85

## The Concentrated View

This short telephoto is a classic portrait focal length which is further enhanced by the long barrel rotation for precise control of the focus point in the image. The **Planar T\* 1,4/85** is optimized for medium to longer distances and provides distortion-free performance, which only improves as the lens is stopped down. The fast f/1.4 aperture is very useful for creatively controlling the depth of field and the nearly circular diaphragm creates a pleasing 'bokeh' in the out-of-focus areas. Combined with a DSLR with a 1.5 crop factor, the lens becomes a focal length of 128 mm.



Picture shows ZE mount

## Planar T\* 1,4/85



We make it visible.



- 1 The shallow depth of field at full aperture provides superior control and allows the subject to be separated from the back- and foreground.
- 2 The precise focusing mechanism focuses the attention on the subject matter.
- 3 The lens design produces brilliant, distortion-free images over the entire frame.

Photo: Michael Ankenbrand

## The Concentrated View

### Technical Specifications

#### Planar T\* 1,4/85

<b>Focal length</b>	85 mm
<b>Aperture range</b>	f/1.4 – f/16 (1/2 stop intervals)
<b>Number of elements/groups</b>	6/5
<b>Focusing range</b>	1 m (3.3 ft) – ∞
<b>Angular field* (diag./horiz./vert.)</b>	29/24/16°
<b>Coverage at close range</b>	36 x 24 cm (14 x 9.4")
<b>Image ratio at close range</b>	1:10
<b>Filter-thread</b>	M 72 x 0.75
<b>Length (with caps)**</b>	85 - 88 mm (3.3 - 3.5")
<b>Diameter**</b>	77 - 78.2 mm (3 - 3.1")
<b>Weight**</b>	600 - 670 g (21 - 24 oz.)
<b>Camera mounts</b>	ZE (EF bayonet) ZF.2 (F bayonet with CPU) ZF (F bayonet) ZK (K bayonet)
<b>Scope of delivery</b>	Lens Shade included

\*referring to 35 mm format

\*\*dimensions and weight may vary according to the camera mount

### Construction

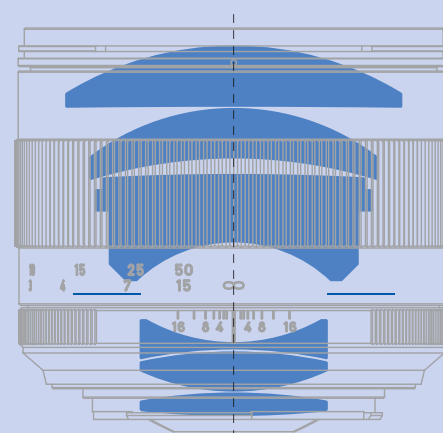

Carl Zeiss AG  
 Camera Lens Division  
 D-73446 Oberkochen · Germany  
[www.zeiss.com/photo](http://www.zeiss.com/photo)

EN\_10\_022\_101 III • Printed in Germany  
 Subject to change.

Carl Zeiss SLR Lenses

# Makro-Planar T\* 2/50

## The Universal High-speed Macro

This macro lens provides a normal perspective and allows for close focusing down to 1:2. The **Makro-Planar T\* 2/50** uses a new lens design which incorporates floating elements to ensure high performance across a wide focusing range. As a result, the lens can be used for non-macro applications and becomes a versatile 'standard' lens when used with a full frame camera. The fast f/2 aperture and distortion-free performance enables wide-open photography with a short depth-of-field without compromising the image quality. Combined with a DSLR with a 1.5 crop factor, the lens becomes a focal length of 75 mm.



Picture shows ZE mount

## Makro-Planar T\* 2/50



We make it visible.





**1** A versatile 'standard' lens for both, macro and non-macro photography.

**2** The floating elements design ensures a virtually unchanged performance from 0.24 m (0.79 ft) to infinity.

**3** A fast f/2 aperture is useful under low-light conditions and gives better creative control of the depth-of-field.

Photo: Michael Ankenbrand

## The Universal High-speed Macro

### Technical Specifications

#### Makro-Planar T\* 2/50

<b>Focal length</b>	50 mm
<b>Aperture range</b>	f/2 – f/22 (1/2 stop intervals)
<b>Number of elements/groups</b>	8/6
<b>Focusing range</b>	0.24 m (0.79 ft) – ∞
<b>Angular field* (diag./horiz./vert.)</b>	45/38/26°
<b>Coverage at close range</b>	72 x 48 mm (28 x 19")
<b>Image ratio at close range</b>	1:2
<b>Filter-thread</b>	M 67 x 0.75
<b>Length (with caps)**</b>	88 - 91 mm (3.5 - 3.6")
<b>Diameter**</b>	72 - 75.4 mm (2.8 - 3")
<b>Weight**</b>	530 - 570 g (19 - 20 oz.)
<b>Camera mounts</b>	ZE (EF bayonet) ZF.2 (F bayonet with CPU) ZF (F bayonet) ZK (K bayonet)
<b>Scope of delivery</b>	Lens Shade included

\*referring to 35 mm format

\*\*dimensions and weight may vary according to the camera mount

### Construction

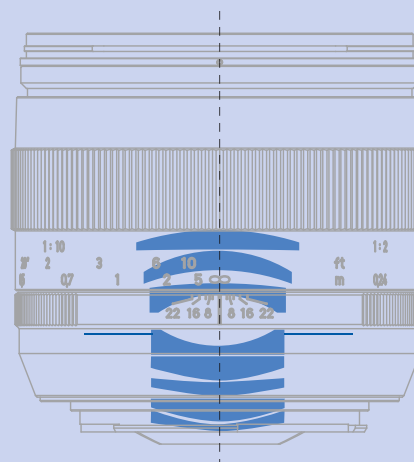

**Carl Zeiss AG**  
**Camera Lens Division**  
 D-73446 Oberkochen · Germany  
[www.zeiss.com/photo](http://www.zeiss.com/photo)

EN\_10\_022\_107 III • Printed in Germany  
 Subject to change.

Carl Zeiss SLR Lenses

# Makro-Planar T\* 2/100

## The Selective Macro Superstar

This extremely fast, short telephoto macro lens can capture even the smallest details with maximum precision. The **Makro-Planar T\* 2/100** features a completely new optical design which incorporates floating lens elements to ensure distortion-free, maximum imaging performance throughout the focusing range. As a result, this lens is well-suited for macro photography and is also a superb portrait lens. An extremely wide and smooth focusing rotation provides superior control and the fast f/2.0 aperture allows for a short depth of field to draw attention to the subject. When used with a DSLR with a 1.5 crop factor, the lens has an effective focal length of 150 mm.



Picture shows ZE mount



## Makro-Planar T\* 2/100



We make it visible.



**1** Extremely fast macro featuring a completely new optical design.

**2** The floating elements design ensures a high-quality image throughout the entire focusing range.

**3** Precision mechanics and a very large angle of rotation enable the photographer to very precisely focus on the details in the image.

Photo: Michael Ankenbrand

## The Selective Macro Superstar

### Technical Specifications

#### Makro-Planar T\* 2/100

<b>Focal length</b>	100 mm
<b>Aperture range</b>	f/2 – f/22 (1/2 stop intervals)
<b>Number of elements/groups</b>	9/8
<b>Focusing range</b>	0.44 m (1.4 ft) – ∞
<b>Angular field* (diag./horiz./vert.)</b>	25/21/14°
<b>Coverage at close range</b>	72 x 48 mm (28 x 19")
<b>Image ratio at close range</b>	1:2
<b>Filter-thread</b>	M 67 x 0.75
<b>Length (with caps)**</b>	113 - 115 mm (4.4 - 4.5")
<b>Diameter**</b>	76 mm (3")
<b>Weight**</b>	680 g (24 oz.)
<b>Camera mounts</b>	ZE (EF bayonet) ZF.2 (F bayonet with CPU) ZF (F bayonet) ZK (K bayonet)
<b>Scope of delivery</b>	Lens Shade included

\*referring to 35 mm format

\*\*dimensions and weight may vary according to the camera mount

### Construction

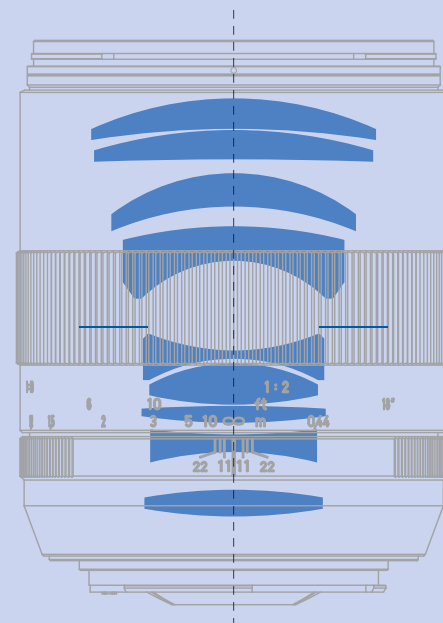

Carl Zeiss AG  
Camera Lens Division  
D-73446 Oberkochen · Germany  
[www.zeiss.com/photo](http://www.zeiss.com/photo)

EN\_10\_022\_108 III • Printed in Germany  
Subject to change.