

**OPERATION MANUAL
OF MODEL TH2681/A
HIGH RESISTANCE TESTER**

CONTENTS

I. Generals	3
II. Main Technical Data	4
III. Description of Panel Function	8
IV. Instruction of Operation	9
V. Calibration, Inspection and Maintenance of the Tester	11
VI. Warranty of the Tester	13

I. Generals

1.1 Brief Introduction of the Product

Model TH2681/2681A High Resistance Tester is a measuring instrument used to measure insulation features of various kinds of electronic component, media materials and the complete set etc. It has features of fast measurement, good stability and easy operation, as well as the sorting function.

This tester is in accord with the requirement in Group II of the Standard GB6587.1 《General Outline for Electronic Measurement Instrument in Environmental Experiment》 of the Ministry of Electronic Industry. The rated conditions for application are as follows:

A: Environment Temperature: (0~40)°C

B: Relative Humidity: <70%

C: Atmosphere Pressure: 86-106 kPa

1.2 Confirmation of Attachments before Application

When receiving the tester, you are pleased to confirm following items so as to protect your right.

A: If the appearance of the product is imperfection such as broken, scraped etc.

B: If standard attachments listed in the table below are missing or not.

Should above damage or insufficient attachments be found, please let our company or affiliates, office or agent know so as to provide you service immediately.

Name of Item	Materials	Quantity	Remarks
Power Supply Wire		1	
Measuring Wire		1	Normal measuring clip wire
Operation Manual		1	
Measuring Seat			Option item

1.3 Ambient Environment of Application

1.3.1 Please do not use the tester in place where subjects to dust and vibration and those place under direct daylight or corrosive gas. You are pleased to use the tester in the place where ambient temperature is between 0°C-40°C and relative humidity is less than 70%.

1.3.2 In order to prevent temperature rising inside the tester, take care of ventilation around it and keep it more than 10 cm away from the wall or object. The left and right ventilation holes of Tester cannot be covered so as to maintain high accuracy of the instrument.

1.3.3 As the tester has some design against disturbance of AC power supply, it is still suggested to use the tester under the environment with less disturbance. Should disturbance not be avoided, please add the filter device of power supply.

1.3.4 The storage range of temperature for the instrument is between -25°C~70°C. Should the instrument not be used for a long period, it should be packed with the original packing materials or something similar and stored in the place where is dry and free of direct sunlight so as to maintain its high accuracy when it is reused.

1.4 Voltage of Power Supply

Before switching on the power supply, be sure that the switch of power is in the OFF position and the applied voltage is within the range of specified voltage. The voltage of power supply is $220(1 \pm 10\%)V$ and the frequency of power supply is 50 Hz or 60 Hz.

1.5 Fuse

There is a fuse holder on the rear panel of the instrument. Be attention when changing the fuse:

- 1.5.1 Make sure to switch OFF the power supply first and draw out the wire of power supply.
- 1.5.2 Visual inspection of the fuse cannot be confirmed. It is normal when measured resistance value is under 15Ω .
- 1.5.3 When changing the fuse, slightly press the outer cap of the fuse holder, which is projected from the rear panel, and turn it counterclockwise until the fuse pops out.
- 1.5.4 Take out the outer cap and replace the fuse with the new one (same specifications with that of the origin).
- 1.5.5 Slightly press the outer cap into the fuse holder and turn it clockwise.

1.6 Preheating Time

All functions of the tester are available as long as the tester is switched on, however in order to obtain the specified accuracy, you are pleased to preheating it for about 30 minutes.

II. Main Technical Data

2.1 Measuring Voltage: special demand for detailed voltage range is available upon request.

TH2681:	Voltage	Voltage multiple
	10V	$\times 0.1$
	25V	$\times 0.25$
	50V	$\times 0.5$
	100V	$\times 1$
	250V	$\times 2.5$
	500V	$\times 5$

TH2681A:	Voltage	Voltage multiple
	10V	$\times 0.1$
	50V	$\times 0.5$
	100V	$\times 1$
	250V	$\times 2.5$
	500V	$\times 5$
	1000V	$\times 10$

The accuracy of measuring voltage: $\pm 2\%$ (open circuit state of measuring terminals);

2.2 Range of Measurement

TH2681:	Test voltage	Range of measurement($10^5 \Omega \sim 5 \times 10^{12} \Omega$)
	10V	0.1M Ω ~ 100G Ω
	25V	0.25M Ω ~ 250G Ω
	50V	0.5M Ω ~ 500G Ω
	100V	1M Ω ~ 1T Ω
	250V	2.5M Ω ~ 2.5T Ω
	500V	5M Ω ~ 5T Ω

TH2681A:	Test voltage	Range of measurement($10^5 \Omega \sim 10^{13} \Omega$)
	10V	0.1M Ω ~ 100G Ω
	50V	0.5M Ω ~ 500G Ω
	100V	1M Ω ~ 1T Ω
	250V	2.5M Ω ~ 2.5T Ω
	500V	5M Ω ~ 5T Ω
	1000V	10M Ω ~ 10T Ω

2.3 Accuracy of Measurement

Resistance Value	< 10G Ω	$\pm 3 \% \pm 0.5$ division
Resistance Value	$\geq 10G \Omega$	$\pm 6 \% \pm 0.5$ division
Resistance Value	> 1T Ω	$\pm 10 \% \pm 0.5$ division

2.4 Charging Time

For electronic complete set, materials and resistance component: charging time < 0.1 second

Capacitor: charging time from 0.5 second to 10 seconds

2.5 Limit range:

Limit = (1.0 ~ 9.9) \times selected multiples of voltage \times multiple switch (M Ω)

Accuracy: $\pm 3 \% \pm 0.5$ division

2.6 Sorting Function

This instrument has sorting function. The required value can be pre-selected by the dial switch.

When measuring value is less than the preset value, “No-Good” lamp will light plus sound prompt (can be turned off) which means fail. When measuring value is larger than the preset value, “No-Good ” lamp will go out and that means pass.

2.7 Select which to be indicated by Head Indication

When Set/Measure button is released, the value indicated by the head is that preset by the dial.

When Set/Measure button is pressed, the value indicated by the head is that to be measured.

2.8 Selection between Measuring and Discharging State

When the band switch of voltage selection is in the **discharge** position, the measured component shall be discharged by a resistor of 5W/1k Ω inside the tester, and no voltage is applied to the terminals.

2.9 Conditions of Application:

2.9.1 Temperature: 0 $^{\circ}$ C~40 $^{\circ}$ C; Relative Humidity: less than 70%

2.9.2 Storage Temperature: -25 $^{\circ}$ C~70 $^{\circ}$ C

2.9.3 Voltage of Power Supply: 220(1 \pm 10%)V

Frequency: 50Hz or 60Hz

Power: 50VA.

2.10 Dimensions and Weight

2.10.1 Dimensions: 300mm (length) \times 270mm (width) \times 180mm (height)

2.10.2 Weight: about 3 kg.

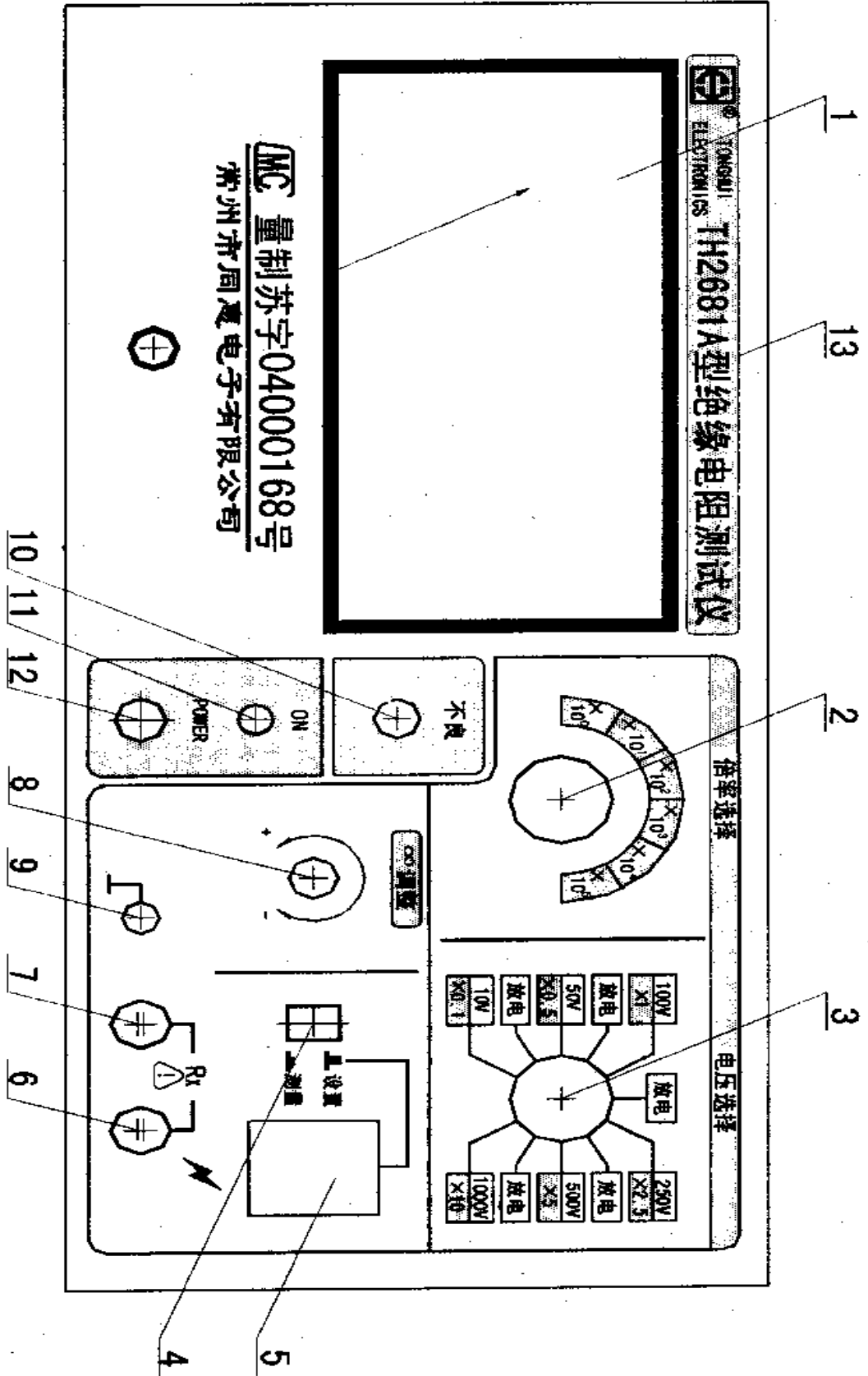

III. Description of Front Panel

3.1 The Head of the Tester: Model TH2681/TH2681A Insulation Resistance Head (also 100 μ A Current Head);

3.2 Multiple Selection Switch: there are 6 grades for multiple selection: $\times 10^0$, $\times 10^1$, $\times 10^2$, $\times 10^3$, $\times 10^4$, $\times 10^5$;

3.3 Voltage Selection Switch: there are 11 grades in which 6 for voltage selection and 5 for discharging:

TH2681: 10V/25V/50V/100V/250V/300V

TH2681A: 10V/50V/100V/250V/500V/1000V

3.4 Set/Measurement Switch: selection for indication state of the head;

Set/Measurement Switch in Set position: the value indicated by the head is that preset by the dial;

Set/Measurement Switch in Measurement position: the value indicated by the head is that to be measured.

3.5 Setting of the Dial

It consists of two bits , and is used to preset the limit value of component for sorting.

3.6 Output Terminals of Voltage

It outputs negative high voltage and is connected to one end of measuring wire. Take care of safety due to output of high voltage.

3.7 Measuring terminals: to be connected to the other end of measuring wire.

3.8 “ ∞ ” Adjusting Potentiometer

It can adjust range of each multiples to make the pointer of the insulation tester indicate “ ∞ ”.

3.9 Grounding Terminal

3.10 Failure Indicating Lamp

When it lights, it means the insulating resistance of measured component is less than the preset value, and the component is not good.

When it doesn't light, it means the insulating resistance of measured component is larger than the preset value, and the component is good one.

3.11 Indicating Lamp of Power Supply

3.12 Switch of Power Supply

3.13 Model, name and Trade Mark

Model of the Tester: TH2681 or TH2681A

Name: High Resistance Tester

Trade Mark: trade mark of product of Tonghui Electronic Co., Ltd

IV. Instruction of Operation

It is suggested that customer should read this operation manual carefully before application so as to be familiar with its operating method and working principle.

4.1 Measuring Method of the Object to be Measured

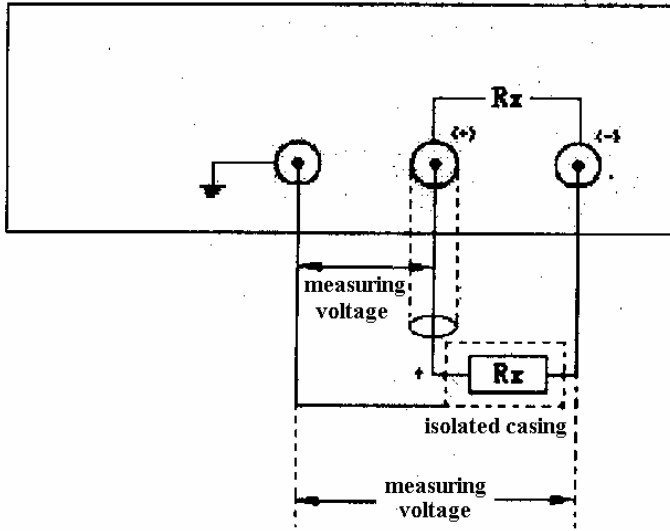

!!!
— NOTICE —

1. When measuring, take care of safety due to high voltage on both ends of the object to be measured.
2. Take care of correct connection if the object to be measured has polarity.
3. In order to obtain correctness and stability of measurement, isolation of environment and control of temperature and humidity should be done well.
4. The shielded wire on the measuring end (+) should not be connected with the casing of the instrument.

4.2 Notice before Measuring

4.2.1

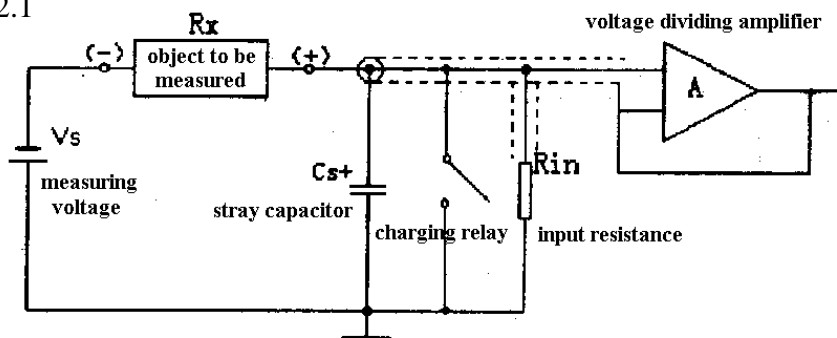

Equivalent Electrical Circuit of Measurement

Multiple	Input Resistance
10^0	1k Ω
10^1	10k Ω
10^2	100k Ω
10^3	1M Ω
10^4	10M Ω
10^5	100M Ω

4.2.2 Above drawing is equivalent circuit in which the input resistance has relation with the multiple and is shown as the table. The measurement range of the object to be measured has relation with voltage and multiple and shown as follows:

TH2681:

Unit: Ω

multiple range voltage	10^0	10^1	10^2	10^3	10^4	10^5
	10V	100K-1M	1M-10M	10M-100M	100M-1G	1G-10G
25V	250K-2.5M	2.5M-25M	25M-250M	250M-2.5G	2.5G-25G	25G-250G
50V	500K-5M	5M-50M	50M-500M	500M-5G	5G-50G	50G-500G
100V	1M-10M	10M-100M	100M-1G	1G-10G	10G-100G	100G-1T
250V	2.5M-25M	25M-250M	250M-2.5G	2.5G-15G	25G-250G	250G-2.5T
500V	5M-50M	50M-500M	500M-5G	5G-50G	50G-500G	50G-5T

TH2681A:

Unit: Ω

multiple range voltage	10^0	10^1	10^2	10^3	10^4	10^5
10V	100K-1M	1M-10M	10M-100M	100M-1G	1G-10G	10G-100G
50V	500K-5M	5M-50M	50M-500M	500M-5G	5G-50G	50G-500G
100V	1M-10M	10M-100M	100M-1G	1G-10G	10G-100G	100G-1T
250V	2.5M-25M	25M-250M	250M-2.5G	2.5G-15G	25G-250G	250G-2.5T
500V	5M-50M	50M-500M	500M-5G	5G-50G	50G-500G	50G-5T
1000V	10M-100M	100M-1G	1G-10G	10G-100G	100G-1T	1T-10T

M: 10^6 G: 10^9 T: 10^{12}

Data Table of Voltage, Multiple and Measuring Range

4.2.3 There is an adjuster in the front panel, which is used to make sure that head pointer should point to “ ∞ ” for each multiple range when test terminals are open circuit.

For the multiple range of $\times 10^5$:

- When measuring terminals have no measuring fixture or no measuring wires connected, the head pointer should point to “ ∞ ”.
- When measuring terminals have measuring fixture or measuring wires connected but no object Rx is connected, the head pointer may have some drift, because the feedback resistance of this range is as larger as $100M \Omega$, which is caused from disturbance signal received by the “antenna”, i.e. measuring wires.

When Rx is connected, external stray signals will disappear, and the correctness of measurement in this range will not be affected.

4.3 Set up Measurement Data

4.3.1 Voltage select

According to technical requirement of product, set the voltage band switch to corresponding voltage grade. Take care that the measuring fixture is live now and is dangerous.

4.3.2 Multiple select

Set relative multiple according to the relation drawing in Section 4.2.2.

4.3.3 Upper Limit set up

According to technical requirement of product, set the value of the dial switch, which should correspond to the value of the head pointer. For example, if the value is 2.0, the head pointer should point to 2.0 as well, but the lower limit of insulating resistance is not 2.0. For example, if selected voltage is 250V, selected multiple is $\times 10^2$, selected value of the dial is 2.0, then the lower limit shall be:

$$(2.0 \times 10^2 \times 2.5)M \Omega = 500 M \Omega .$$

4.4 Example

One factory needs to sort a lot of metal-film capacitor, its specification is CBB-250V- 2.2 μ F and insulation resistance $R_x > 100G$.

4.4.1 Turn on the power supply , the power lamp lights. Preheat for 15 minutes before test.

4.4.2 Turn the voltage select switch to 250V position, then 250V voltage will be outputted from measuring terminals.

Based on Table 4.2.2, select multiple switch at $\times 10^4$ grade,

Lower limit is $100G \Omega$, and the dial switch value will be:

$$100 \times 10^9 / (2.5 \times 10^4 \times 10^6) = 4.0$$

4.4.3 Connect the measuring fixture provided by our company and begin measurement.

4.4.4 Discharge the measured capacitor. It is suggested to discharge outside the instrument as it needs certain discharging time due to that there is a $1 k\Omega$ discharge resistor inside the instrument.

V. Calibration, Inspection and Maintenance of the Tester

5.1 Creation and Check of DC voltage

5.1.1 Creation of 10V

It is provided by resistors R18, R9 and adjuster W1. The accuracy can be adjusted by adjusting W1.

5.1.2 Creation of other voltages (For example of TH2681A)

5V voltage is created by the voltage stabilizer V20. As the pin 3 of N1 is a virtual ground, so its level is 0V. The constant current is determined by R17 and W2 and can be adjusted to 1mA by adjusting W2. When 1mA current flows through ,different voltages can be acquired from R51, R52, R53, R54, R55, R56, R57 and R58 in which 50V voltage from R51, 100V from R52, 250V from R53 and R54, 500V from R55 and R56, 1000V from R57 and R58.

5.1.3 Should voltage created has larger error or voltage cannot be created, check all components in Section 5.1.2 to see if they are correct. Check components N1, V27, V28 and V29 and resistors and diodes around them to see if they are damaged, and replace them if necessary.

5.1.4 Check connection wires as the drawing below. Its measurement should meet requirement stipulated in Section 2.1. Should it not met, check feature and accuracy of components in Sections 5.1.1 to 5.1.3.

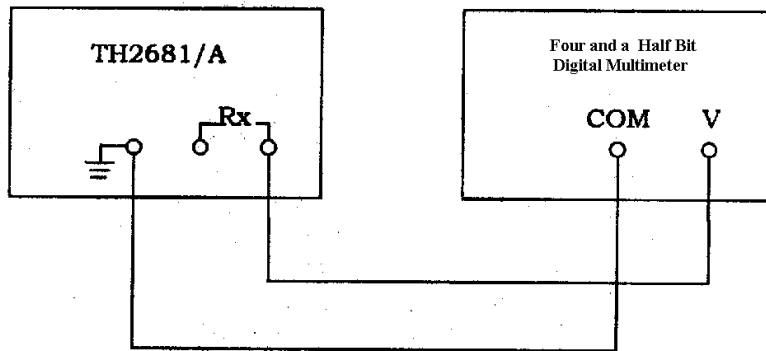

5.2 Inspection of Maximum Charging Current

- 5.2.1 When the tester make charge over measured component, it is a constant current and $I = 20\text{mA}$ which is decided by circuit N2, R44, 425 and R2. The value $I = R2 \times V_{cc} / (R12 \times R44)$.
- 5.2.2 The inspection of maximum charging current is as the drawing below. At this time the voltage grade is at 100V position. The switch K cannot be set at On position for longer time and 10 seconds is suggested. When measurement is completed, set the switch K at OFF position. Should charging current has larger error, customer can make inspection as per Section 5.2.1, and make modification for charging current as per Section 5.2.1 if needed, and only the ratio value of resistors R2 and R12 should be modified.

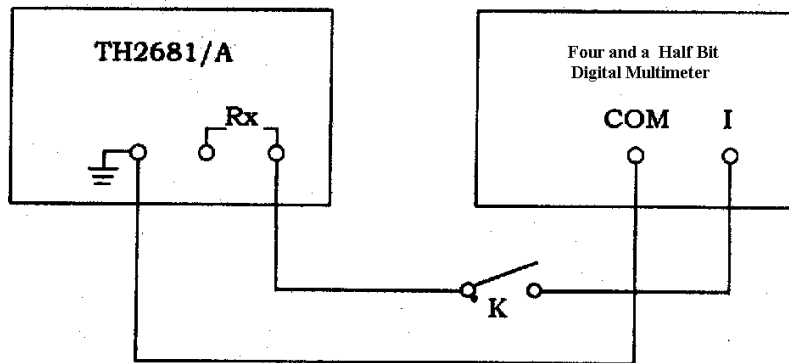

5.3 Inspection of Insulation Resistance

- 5.3.1 Make inspection as per drawing and the table below. Its accuracy should meet requirement stipulated in Section 2.3.

Measuring Voltage	Standard Resistor	Actually Measured Resistance
100V	1M	
	10M	
	100M	
	1G	
	10G	
	100G	

OPERATION MANUAL OF MODEL TH2681/A

Standard Resistor	Measuring Voltage	Actually Measured Resistance
100M	10V	
	25V	
	50V	
	100V	
	500V	
	1000V	

VI. Warranty

This instrument product is warranted against defects in material and workmanship for a period of two years from the date of shipment. The foregoing warranty shall not apply to defects resulting from improper or inadequate maintenance by buyer, buyer-supplied unauthorized modification or misuse, operation outside of the environmental specifications for the product, or improper site preparation or maintenance.